





A4				 <b>台普</b> <b>ROCPCU</b>	COMMON TOLERANCE X.XX ± 0.10 X.X ± 0.15 X ± 0.25 ANGULAR —	UNIT	MM	PROJECTED		PRODUCT NAME:	
A3			DRAWN BY			SHUHAO	CHECKED BY	COCO	MODEL NO: TP91657P□□□□		
A2			DATE			2019	APPROVAL	B	ALEN	Https: www.rocpcu.tw	
A1			<h1>ROCPCU TECHNOLOGY CO.,LTD</h1>								
REV	DATE	REVISION	DESCRIPTION			ISSUE	Copies are issued in strict confidence and shall not be reproduced or copied, or used as the basic of manufacture or sale of apparatus without permission				



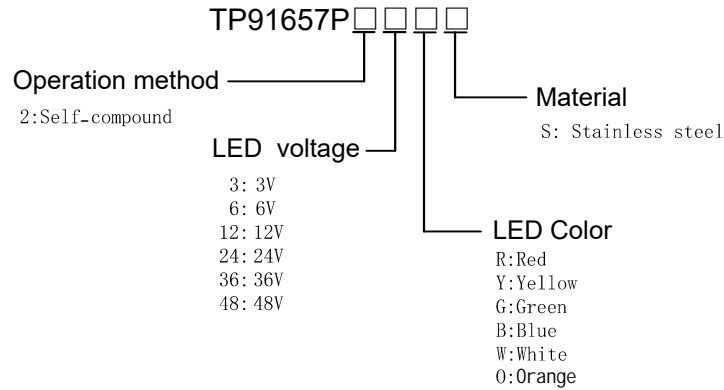

性能参数

1. Heating current: Ui: AC250V, Ith: 5A  
发热电流: Ui: AC250V, Ith: 5A
2. Rated current: 3A/DC36V  
额定电流: 3A/DC36V
3. Insulation resistance: ≥1000MΩ  
绝缘电阻 :≥1000MΩ
4. Contact resistance: ≤50mΩ  
接触电阻 :≤50mΩ
5. Pressing stroke: 0.50mm ± 0.10  
按压行程: 0.50mm ± 0.10
6. Contact stroke: 0.50mm ± 0.10  
接触行程 :0.50mm ± 0.10
7. welding temperature: 320 °C ± 20 °C  
焊接温度: 320 °C ± 20 °C
8. Welding duration: Less than 3 seconds in duration  
焊接时长: Less than 3 seconds in duration
9. Nut assembly torque: 5-14N  
螺帽装配力矩: 5-14N
10. Protection level: IP67

11. Explosion prevention level: IK08  
防暴等级: IK08
12. Working environment temperature: -20 °C ~ +55 °C  
工作环境温度: -20 °C ~ +55 °C
13. Compression torque: ≤ 3N  
按压扭力: ≤ 3N
14. Electrical life: 200000 cycles  
电气寿命: 200000 cycles
15. mechanical: 1000000 cycles  
机械寿命: 1000000 cycles
17. NO reverse thrust foot torque: ≤ 30N  
NO反推脚扭力: ≤ 30N
18. LED lamp power consumption: 20m 以下  
LED灯功耗: 20m 以下
19. LED lamp lifespan: 40000h  
LED寿命: 40000h

A4				 <b>ROCPCU</b>	COMMON TOLERANCE		UNIT	MM	PROJECTED		PRODUCT NAME:
A3					X.XX	± 0.10	DRAWN BY	SHUHAO	CHECKED BY	COCO	MODEL NO: TP91657P□□□□
A2					X.X	± 0.15	DATE	2019	APPROVAL B	ALEN	Https: www.rocpcu.tw
A1					X	± 0.25	<h1>ROCPCU TECHNOLOGY CO., LTD</h1>				
REV	DATE	REVISION	DESCRIPTION		ISSUE	ANGULAR					
	A		B		C		D	E	F	G	

NO 序号	Part name 部件名	Material 材料	QTY 数量	Remark 备注
1	Key 按键	SUS 不锈钢	1	
2	Housing 外壳	SUS 不锈钢	1	
3	Oring O型圈	Silica gel 硅胶	1	
4	Arm nut 固定螺帽	Brass 黄铜	1	nickeling 镀镍
5	Base 基座	PBT	1	
6	Pin 引脚	Brass 黄铜	1	gold-plating 镀金
7	LEDpin LED脚	Brass 黄铜	1	Silvering 镀银
8	luminous zone 发光区	PC 塑料	1	

A4				 <b>ROCPCU</b>	COMMON TOLERANCE		UNIT	MM	PROJECTED		PRODUCT NAME:
A3					X.XX	± 0.10	DRAWN BY	SHUHAO	CHECKED BY	COCO	MODEL NO: TP91657P□□□□
A2					X.X	± 0.15	DATE	2019	APPROVAL B	ALEN	Https: www.rocpcu.tw
A1					X	± 0.25	<b>ROCPCU TECHNOLOGY CO.,LTD</b>				
REV	DATE	REVISION	DESCRIPTION		ISSUE	ANGULAR					