



Schematic Diagram
电气原理图

Installation View
安装视图

A4						COMMON TOLERANCE		UNIT	MM	PROJECTED		PRODUCT NAME:
A3				X.XX		± 0.10	DRAWN BY	SHUHAO	CHECKED BY	COCO	MODEL NO: TP991903P <input type="checkbox"/> <input type="checkbox"/> <input type="checkbox"/> <input type="checkbox"/>	
A2				X.X		± 0.15	DATE	2019	APPROVAL B	ALEN	Https: www.rocpcu.tw	
A1				X		± 0.25	<h1>ROCPCU TECHNOLOGY CO.,LTD</h1>					
REV	DATE	REVISION	DESCRIPTION	ISSUE		ANGULAR						<small>Copies are issued in strict confidence and shall not be reproduced or copied, or used as the basic of manufacture or sale of apparatus without permission</small>

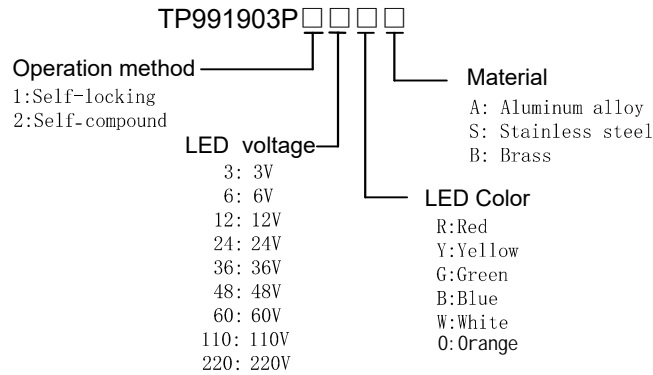

连接形式



- Welding temperature of wire: 320 ± 20 °C
 线材焊接温度: 320±20°C
 Wire welding duration: less than 3 seconds
 线材焊接时长: 时长3秒以下
- Can be used with dedicated connectors:
 可配专用接插件使用:
 - Switch function wire: Blue wire (NO) (1.0²mm)
 开关功能线材: 蓝线 (NO) (1.0²mm)
 - LED functional wire: red wire positive pole black wire negative pole(0.5²mm)
 LED功能线材: 红线正极 黑线负极(0.5²mm)
 - LED is an electrodeless lamp bead that can be lit without the need to separate positive and negative poles
 LED为无极灯珠, 无需分正负极也可点亮

性能参数

- Heating current: Ui: AC250V, Ith: 10A
 发热电流: Ui: AC250V, Ith: 10A
- Rated current:10A,AC110V/220V
 10A,DC12V/24V
 额定电流:10A,AC110V/220V
 10A,DC12V/24V
- Power-frequency withstand voltage:1500V/1min
 工频耐压:1500V/1min
- Insulation resistance:≥1000MΩ
 绝缘电阻 :≥1000MΩ
- Contact resistance:≤50mΩ
 接触电阻 :≤50mΩ
- Pressing stroke:4.00mm ± 0.10
 按压行程:4.00mm ± 0.10
- Contact stroke:1.20mm±0.10
 接触行程 :1.20mm±0.10
- welding temperature: 320 °C± 20 °C
 焊接温度: 320 °C± 20 °C
- Welding duration: Less than 3 seconds in duration
 焊接时长: Less than 3 seconds in duration
- Nut assembly torque:5-14N.m



螺帽装配力矩:5-14N.m

- Protection level:IP67
 防护等级:IP67
- Explosion prevention level: IK10
 防暴等级: IK10
- Working environment temperature: -40 °C~+80 °C
 工作环境温度: -40 °C~+80 °C
- Compression torque: ≤ 5.0N
 按压扭力: ≤5.0N
- Electrical life: 50,000 cycles
 电气寿命: 50,000 cycles
- Mechanical: 500,000cycles
 机械寿命: 500,000cycles
- LED lamp power consumption: 20mA以下
 LED灯功耗: 20mA以下
- LED lamp lifespan: 40000h
 LED寿命: 40000h
- NO reverse thrust foot torque: ≤30N
 NO反推脚扭力: ≤30N

A4				 台普 ROCPCU	COMMON TOLERANCE		UNIT	MM	PROJECTED		PRODUCT NAME:
A3					X.XX	± 0.10	DRAWN BY	SHUHAO	CHECKED BY	COCO	MODEL NO:TP991903P□□□□
A2					X.X	± 0.15	DATE	2019	APPROVAL B	ALEN	Https: www.rocpcu.tw
A1					X	± 0.25	ROCPCU TECHNOLOGY CO.,LTD				
REV	DATE	REVISION	DESCRIPTION		ISSUE	ANGULAR					
	A		B		C		D	E	F	G	

NO 序号	Part name 部件名	Material 材料	QTY 数量	Remark 备注
1	Key 按键	SUS/Aluminum alloy/Brass 不锈钢/铝合金/黄铜	1	
2	Housing 外壳	SUS/Aluminum alloy/Brass 不锈钢/铝合金/黄铜	1	
3	Oring O型圈	Silica gel 硅胶	1	
4	Arm nut 固定螺帽	Brass 黄铜	1	nickeling 镀镍
5	Contact material 接触材质	silver alloy 银合金	1	
6	NOPin NO引脚	Brass 黄铜	1	gold-plating 镀金
7	Base 底座	PBT	1	
8	LEDpin LED引脚	Brass 黄铜	1	Silvering 镀银
9	luminous zone 发光区	PC 塑胶	1	

材质参数

A4				 台普 ROCPCU	COMMON TOLERANCE		UNIT	MM	PROJECTED		PRODUCT NAME:
A3					X.XX	± 0.10	DRAWN BY	SHUHAO	CHECKED BY	COCO	MODEL NO:TP991903P□□□□
A2					X.X	± 0.15	DATE	2019	APPROVAL B	ALEN	Https: www.rocpu.tw
A1					X	± 0.25	ROCPCU TECHNOLOGY CO.,LTD				
REV	DATE	REVISION	DESCRIPTION		ISSUE	ANGULAR					